

BG14 F80-M10

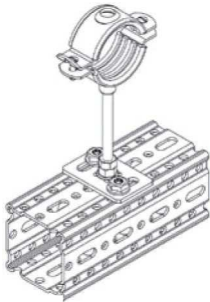

Page 8-8

BG15 F80-M10

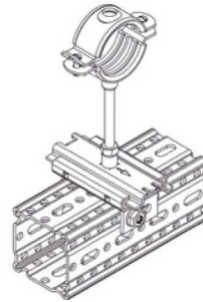

Page 8-9

BG14 F80-1/2"

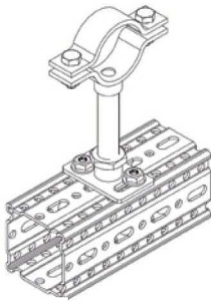

Page 8-10

BG15 F80-1/2"

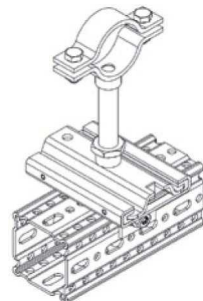

Page 8-11

BG44 F80-M10

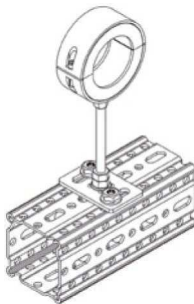

Page 8-12

BG45 F80-M10

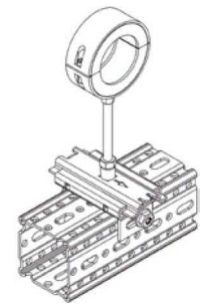

Page 8-13

BG44 F80-1/2"

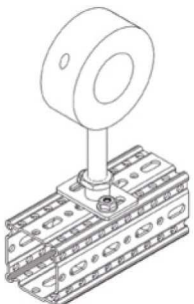

Page 8-14

BG45 F80-1/2"

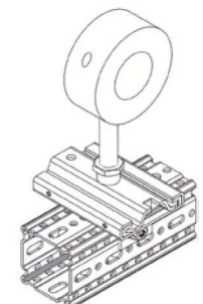

Page 8-15

BG52 F80/100

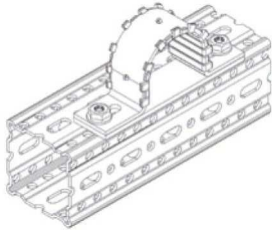

Page 8-16

BG51 F80

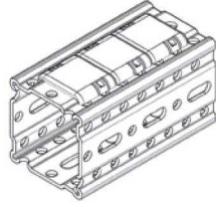

Page 8-17

BG22 F80

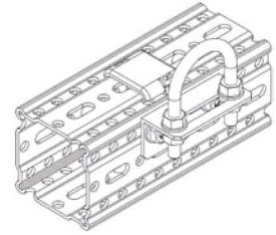

Page 8-18

**BG16 F100-1/2"
2"**

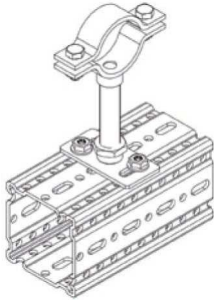

Page 8-19

BG17 F100-1/

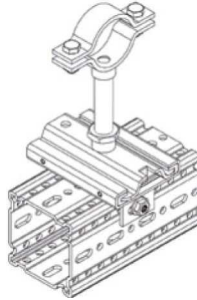

Page 8-20

BG49 F100-1/2"

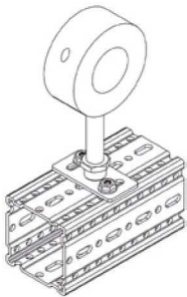

Page 8-21

BG50 F100-1/2"

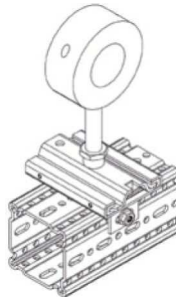

Page 8-22

BG52 F80/100

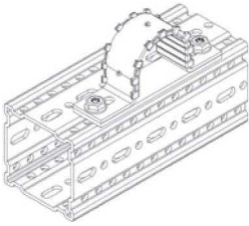

Page 8-23

BG54 F100

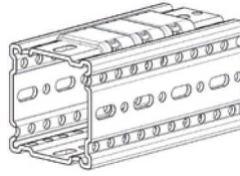

Page 8-24

BG22 F100

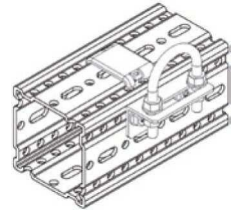

Page 8-25

BG60 T100-1/2"

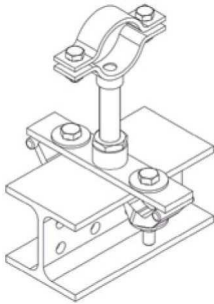

Page 8-26

BG61 T100-1/2"

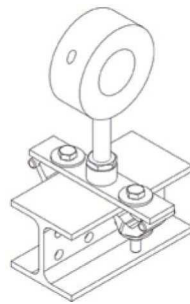

Page 8-27

BG11 MS41-M10

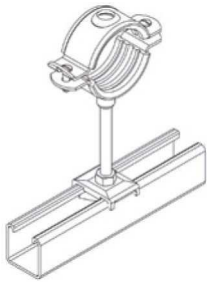

Page 8-28

BG13 MS41-M10

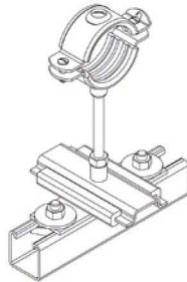

Page 8-29

**BG11 MS41-1/2"
2"**

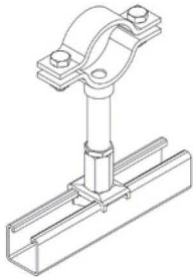

Page 8-30

BG13 MS41-1/

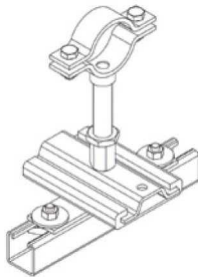

Seite 8-31

BG47 MS41-M10

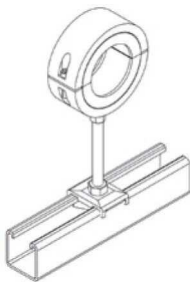

Page 8-32

BG42 MS41-M10

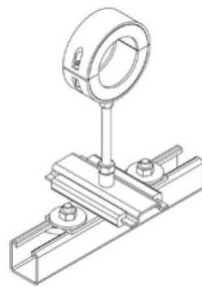

Page 8-33

BG48 MS41-1/2"

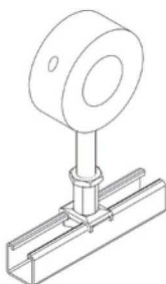

Page 8-34

BG42 MS41-1/2"

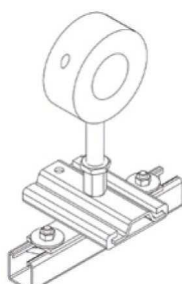

Page 8-35

BG57 MS41

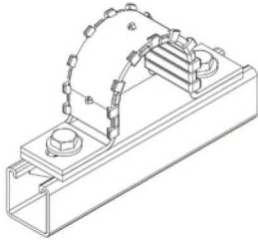

Page 8-36

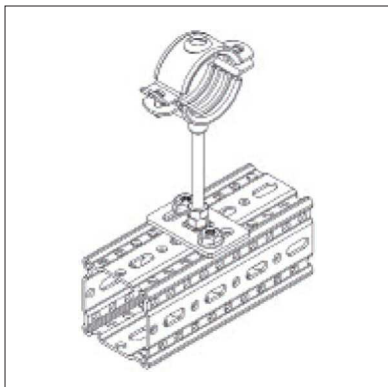

Assembly Group BG14 F80-M10

Application

Assembly Group as fixed pipe connection based on light-duty Pipe Clamp Stabil D3G, suitable for industrial requirements. The secondary steel interface is designed to easily connect the Assembly Group to a Beam Section TP F 80 by using Self Forming Screws FLS F. Height-adjustability is available via the M10 stud. Pipe clamps are lined to meet sound-absorption requirements as per EN DIN 4109.

Scope of delivery

Sikla components are delivered as accumulated pieces goods assorted and separated for each item. Threaded Rod is supplied by the meter (1m Rods) and has to be cut to length on site.

Installation

The installation of Sikla Assembly Groups should be done simultaneously with the line mounting on site.

Parts list

- Pos. 1 Pipe Clamp Stabil D-3G m.E.
- Pos. 2 Threaded Rod GST M10x1000
- Pos. 3 Hexagon Nut NT M10
- Pos. 4 Mounting Plate GPL F80-M10
- Pos. 5 Self Forming Screw FLS F
- Pos. 6 Beam Section TP F80

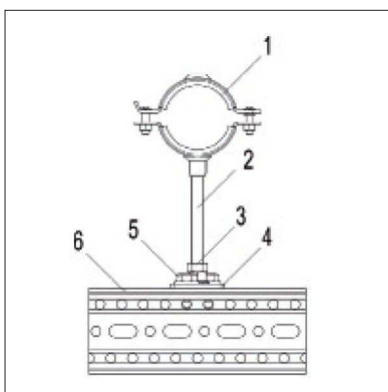

Technical Data

Maximum height $L_{max} = 150$ mm

Material

Plate components: Steel, hcp
 Screws and nuts: Steel, hcp
 Sound Absobtion Elements: SBR/EPDM, black (rubber profile see chapter Sound Absorption Products), captive glued in

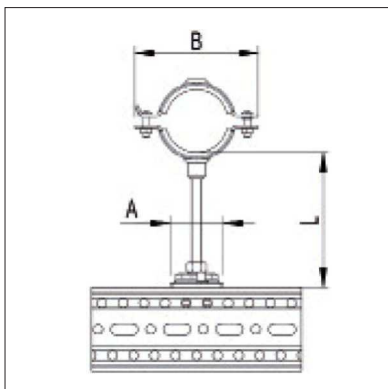

Type	Clamping range [mm]	A [mm]	B [mm]	W [kg]	Quantity [pack]	Part number
DN15	19-23	50	68	0,35	1	110200
DN20	24-28	50	75	0,38	1	110201
DN25	33-37	50	81	0,40	1	110202
DN32	40-45	50	93	0,42	1	110203
DN40	47-52	50	104	0,44	1	110204
DN50	60-65	50	117	0,46	1	110205
DN65	73-78	50	150	0,56	1	110206
DN80	88-93	50	164	0,61	1	110207
DN100	108-115	50	187	0,67	1	110208

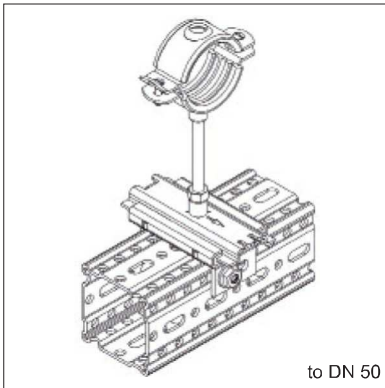

to DN 50

Assembly Group BG15 F80-M10

Application

Assembly Group as guided pipe connection based on light-duty Pipe Clamp Stabil D3G, suitable for industrial requirements. The secondary steel interface is designed to easily connect the Assembly Group to a Beam Section TP F 80 by using Self Forming Screws FLS F. Height-adjustability is available via the M10 stud. Pipe clamps are lined to meet sound-absorption requirements as per EN DIN 4109.

Scope of delivery

Sikla components are delivered as accumulated pieces goods assorted and separated for each item. Threaded Tube is supplied by the meter (1m Rods) and has to be cut to length on site.

Installation

The installation of Sikla Assembly Groups should be done simultaneously with the line mounting on site.

Parts list

- Pos. 1 Pipe Clamp Stabil D-3G m.E.
- Pos. 2 Threaded Rod GST M10x1000
- Pos. 3 Hexagon Nut M10
- Pos. 4 Slide Set GS F80 2G / Slide Set GS F80 2G2
- Pos. 5 Self Forming Screw FLS F
- Pos. 6 Beam Section TP F80

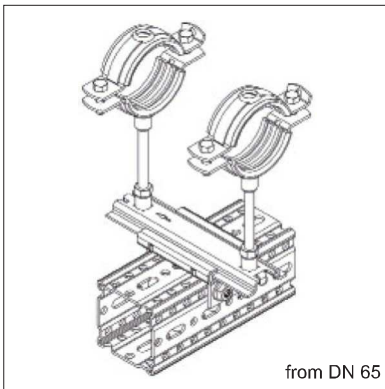

from DN 65

Technical Data

Maximum height $L_{max} = 150$ mm

Material

Plate components: Steel, hcp
 Screws and nuts: Steel, hcp
 Sound Absobtion Elements: SBR/EPDM, black (rubber profile see chapter Sound Absorption Products), captive glued in

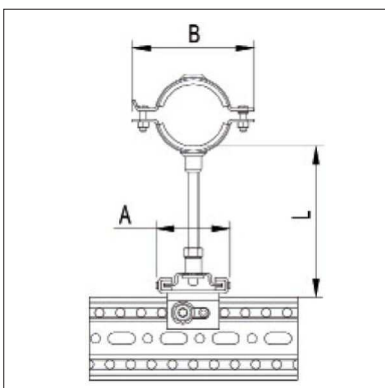
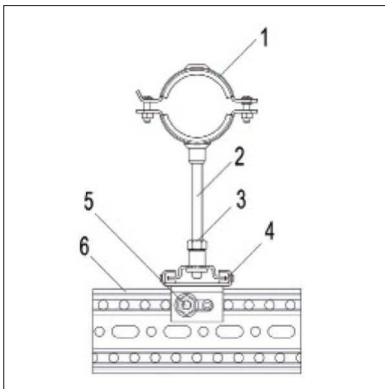

Type	Clamping range [mm]	A [mm]	B [mm]	W [kg]	Quantity [Pack]	Part number
DN15	19-23	67	68	0,86	1	110218
DN20	24-28	67	75	0,89	1	110219
DN25	33-37	67	81	0,91	1	110220
DN32	40-45	67	93	0,93	1	110221
DN40	47-52	67	104	0,95	1	110222
DN50	60-65	67	117	0,97	1	110223
DN65	73-78	67	150	1,55	1	110224
DN80	88-93	67	164	1,65	1	110225
DN100	108-115	67	187	1,77	1	110226

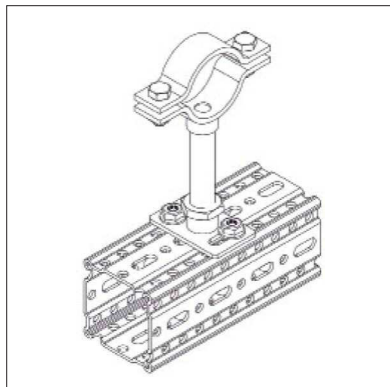

Assembly Group BG14 F80-1/2"

Application

Assembly Group for a fixed pipe connection based on medium-duty Pipe Clamp Stabil I-1/2", suitable for industrial requirements. The secondary steel interface is designed to easily connect the Assembly Group to a Beam Section TP F 80 by using Self Forming Screws FLS F. Height-adjustability is available via the 1/2" Threaded Tube.

Scope of delivery

Sikla components are delivered as accumulated pieces goods assorted and separated for each item. Threaded Tube is supplied by the meter (2m Tubes) and has to be cut to length on site.

Installation

The installation of Sikla Assembly Groups should be done simultaneously with the line mounting on site.

Parts list

- Pos. 1 Pipe Clamp Stabil I-1/2"
- Pos. 2 Threaded Tube GR 2m 1/2"
- Pos. 3 Locking Nut NT G 1/2"
- Pos. 4 Mounting Plate GPL F80-1/2"
- Pos. 5 Self Forming Screw FLS F
- Pos. 6 Beam Section TP F80

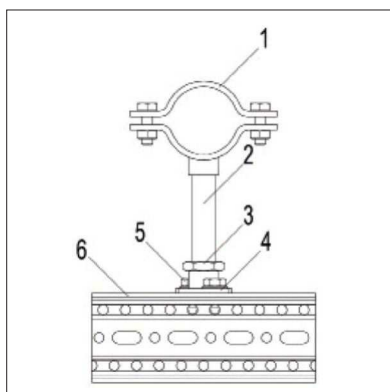

Technical Data

Maximum height $L_{max} = 300$ mm
 Maximum height L_{max} horizontal = 150 mm

Material

Plate components: Steel, hcp
 Screws and nuts: Steel, hcp

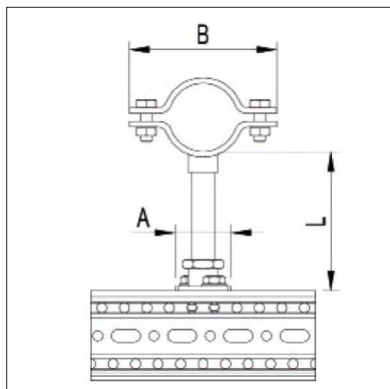

Type	Clamping range [mm]	A [mm]	B [mm]	W [kg]	Quantity [pack]	Part number
DN15	17-22	50	85	0,83	1	110209
DN20	23-27	50	92	0,84	1	110210
DN25	30-34	50	100	0,87	1	110211
DN32	40-44	50	112	0,91	1	110212
DN40	45-49	50	117	0,93	1	110213
DN50	57-61	50	139	1,15	1	110214
DN65	73-77	50	156	1,23	1	110215
DN80	85-89	50	168	1,29	1	110216
DN100	109-115	50	194	1,58	1	110217

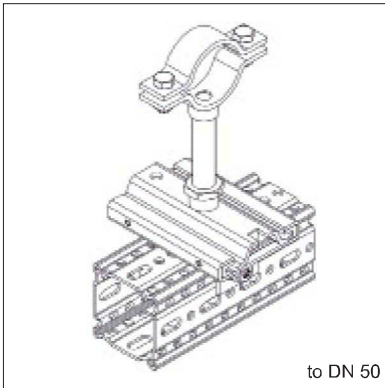

to DN 50

Assembly Group BG15 F80-1/2"

Application

Assembly Group for a guided pipe connection based on medium-duty Pipe Clamp Stabil I-1/2", suitable for industrial requirements. The secondary steel interface is designed to easily connect the Assembly Group to a Beam Section TP F 80 by using Self Forming Screws FLS F. Height-adjustability is available via the 1/2" Threaded Tube.

Scope of delivery

Sikla components are delivered as accumulated pieces goods assorted and separated for each item. Threaded Tube is supplied by the meter (2m Tubes) and has to be cut to length on site.

Installation

The installation of Sikla Assembly Groups should be done simultaneously with the line mounting on site.

Parts list

- Pos. 1 Pipe Clamp Stabil I-1/2"
- Pos. 2 Threaded Tube GR 2m 1/2"
- Pos. 3 Locking Nut NT G 1/2"
- Pos. 4 Slide Set GS F80 1G / Slide Set GS F80 1G2
- Pos. 5 Self Forming Screw FLS F
- Pos. 6 Beam Section TP F80

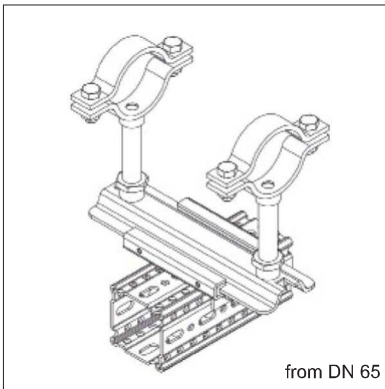

from DN 65

Technical Data

Maximum height $L_{max} = 200$ mm

Material

Plate components: Steel, hcp
Screws and nuts: Steel, hcp

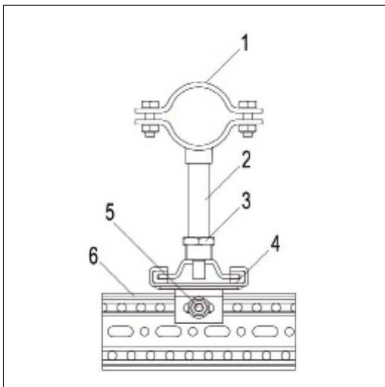

Type	Clamping range [mm]	A [mm]	B [mm]	W [kg]	Quantity [pack]	Part number
DN15	16-22	102	85	1,98	1	110227
DN20	23-27	102	92	1,99	1	110228
DN25	30-34	102	100	2,02	1	110229
DN32	39-44	102	112	2,06	1	110230
DN40	44-49	102	117	2,08	1	110231
DN50	57-61	102	139	2,30	1	110232
DN65	73-77	102	156	3,74	1	110233
DN80	85-89	102	168	3,86	1	110234
DN100	109-116	102	194	4,44	1	110235

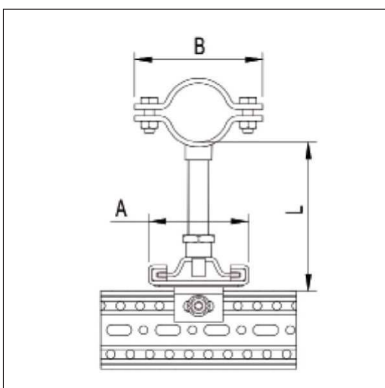

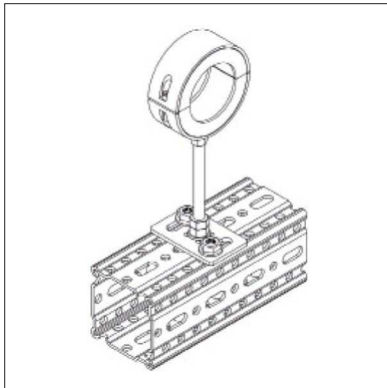

Assembly Group BG44 F80-M10

Application

Assembly Group for a fixed pipe connection based on an insulated Chilled Water Clamp KSH, suitable for industrial chilled water systems. The secondary steel interface is designed to easily connect the Assembly Group to a Beam Section TP F 80 by using Self Forming Screws FLS F. Height-adjustability is available via the M10 stud.

Scope of delivery

Sikla components are delivered as accumulated pieces goods assorted and separated for each item. Threaded Rod is supplied by the meter (1m Rods) and has to be cut to length on site.

Installation

The installation of Sikla Assembly Groups should be done simultaneously with the line mounting on site.

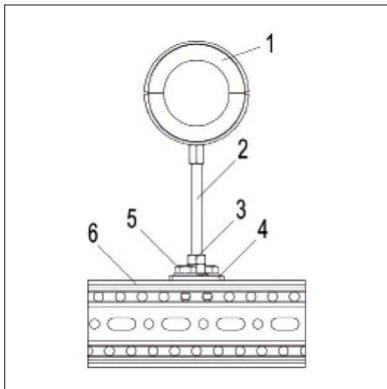

Parts list

- Pos. 1 Chilled Water Clamp KSH
- Pos. 2 Threaded Rod GST M10x1000
- Pos. 3 Hexagon Nut NT M10
- Pos. 4 Mounting Plate GPL F80-M10
- Pos. 5 Self Forming Screw FLS F
- Pos. 6 Beam Section TP F80

Technical Data

Maximum height Lmax = 150 mm

Material

Plate components: Steel, hcp
 Screws and nuts: Steel, hcp
 Clamp material: Steel, electro-galvanised
 Insulation insert: PUR-foam (250 kg/m³, B2), λ = 0,042 W/mK (0°C), Impermeable diffusion resistance
 Fire resistance: closed-cell caoutchouc, B1
 Sound Absorption Elements: closed-cell polyurethane foam, B1
 Temperature range: -40°C bis +105°C

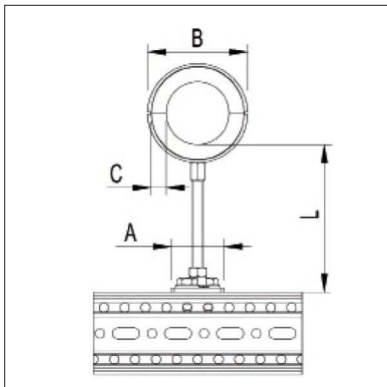

Type	nominal width [DN]	A [mm]	B [mm]	C [mm]	W [kg]	Quantity [Pack]	Part number
KSH 21	15	50	55	13	0,36	1	110277
KSH 27	20	50	63	14	0,37	1	110278
KSH 33	25	50	70	14	0,38	1	110279
KSH 42	32	50	84	15	0,41	1	110280
KSH 48	40	50	84	15	0,41	1	110281
KSH 60	50	50	96	15	0,43	1	110282

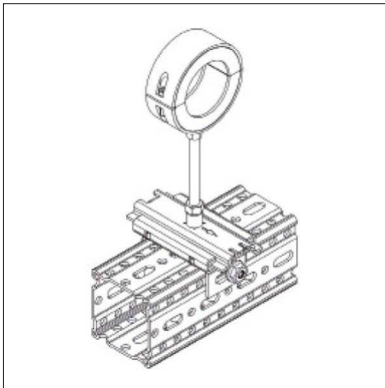

Assembly Group BG45 F80-M10

Application

Assembly Group as guided pipe support with insulated Chilled Water Clamp KSH or Refrigeration and chilled water system for use in industrial plant engineering. The attachment of the assembly is specially designed for the connection with Beam Section siFramo 80 and is bolt with the Self Forming Screw FLS F. Height-adjustability is available via the M10 stud.

Scope of delivery

Sikla components are delivered as accumulated pieces goods assorted and separated for each item. Threaded Rod is supplied by the meter (1m Rods) and has to be cut to length on site.

Installation

The installation of Sikla Assembly Groups should be done simultaneously with the line mounting on site.

Parts list

- Pos. 1 Chilled Water Clamp KSH
- Pos. 2 Threaded Rod GST M10x1000
- Pos. 3 Hexagon Nut NT M10
- Pos. 4 Slide Set GS F80 2G
- Pos. 5 Self Forming Screw FLS F
- Pos. 6 Beam Section TP F80

Technical Data

Maximum height $L_{max} = 150 \text{ mm}$

Material

- Plate components: Steel, hcp
- Screws and nuts: Steel, hcp
- Clamp material: Steel, electro-galvanised
- Insulation insert: PUR-foam (250 kg/m^3 , B2), $\lambda = 0,042 \text{ W/mK}$ (0°C), Impermeable diffusion resistance
- Fire resistance: closed-cell caoutchouc, B1
- Sound Absorption Elements: closed-cell polyurethane foam, B1
- Temperature range: -40°C bis $+105^\circ\text{C}$

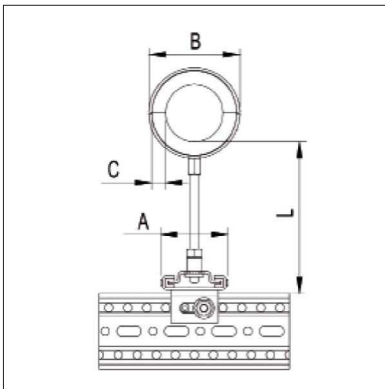
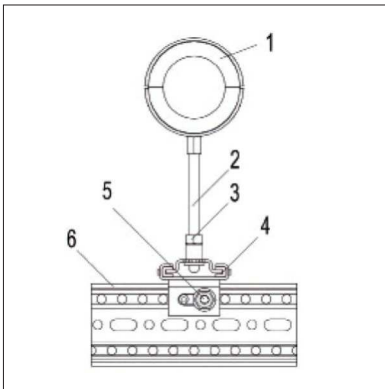

Type	nominal width [DN]	A [mm]	B [mm]	C [mm]	W [kg]	Quantity [Pack]	Part number
KSH 21	15	67	55	13	0,87	1	110293
KSH 27	20	67	63	14	0,88	1	110294
KSH 33	25	67	70	14	0,89	1	110295
KSH 42	32	67	84	15	0,92	1	110296
KSH 48	40	67	84	15	0,92	1	110297
KSH 60	50	67	96	15	0,94	1	110298

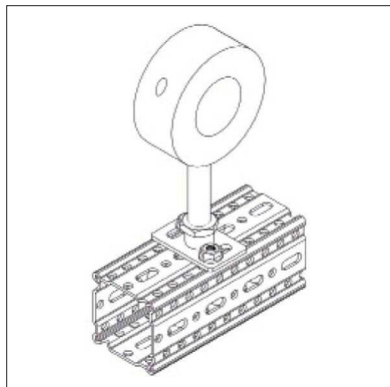

Assembly Group BG44 F80-1/2"

Application

Assembly Group for a fixed pipe connection based on an insulated Chilled Water Clamp RB, suitable for industrial chilled water systems. The secondary steel interface is designed to easily connect the Assembly Group to a Beam Section TP F 80 by using Self Forming Screws FLS F. Height-adjustability is available via the 1/2" Threaded Tube.

Scope of delivery

Sikla components are delivered as accumulated pieces goods assorted and separated for each item. Threaded Tube is supplied by the meter (2m Tubes) and has to be cut to length on site.

Installation

The installation of Sikla Assembly Groups should be done simultaneously with the line mounting on site.

Parts list

- Pos. 1 Chilled Water Clamp RB
- Pos. 2 Threaded Tube G 1/2"
- Pos. 3 Locking Nut NT G 1/2"
- Pos. 4 Mounting Plate GPL F80-1/2"
- Pos. 5 Self Forming Screw FLS F
- Pos. 6 Beam Section TP F80

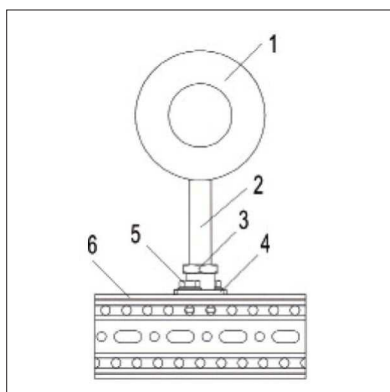

Technical Data

Maximum height $L_{max} = 300$ mm
 Maximum height $L_{max \text{ horizontal}} = 150$ mm

Material

Plate components: Steel, hcp
 Screws and nuts: Steel, hcp
 Insulation insert: PUR-foam (250 kg/m³, B2), $\mu = 1200$,
 $\lambda = 0,045$ W/mK bei (0°C)
 Temperature range: -50°C bis +105°C

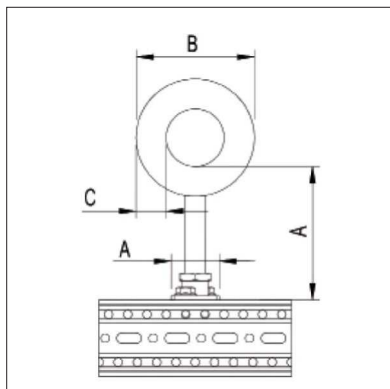

Type	nominal width [DN]	A [mm]	B [mm]	C [mm]	W [kg]	Quantity [pack]	Part number
21/30	15	50	81	30	0,73	1	110283
27/30	20	50	87	30	0,73	1	110284
33/30	25	50	93	30	0,74	1	110285
42/30	32	50	102	30	0,75	1	110286
48/30	40	50	108	30	0,75	1	110287
60/30	50	50	120	30	0,84	1	110289
76/30	65	50	136	30	0,96	1	110290
89/30	80	50	149	30	1,01	1	110291
114/40	100	50	195	30	1,59	1	110292

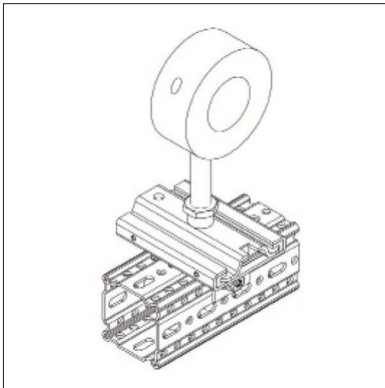

Assembly Group BG45 F80-1/2"

Application

Assembly Group as guided connection based on an insulated Chilled Water Clamp RB, suitable for industrial chilled water systems. The secondary steel interface is designed to easily connect the Assembly Group to a Beam Section TP F80 by using Self Forming Screws FLS F. Height-adjustability is available via the 1/2" Threaded Tube.

Scope of delivery

Sikla components are delivered as accumulated pieces goods assorted and separated for each item. Threaded Tube is supplied by the meter (2m Tubes) and has to be cut to length on site.

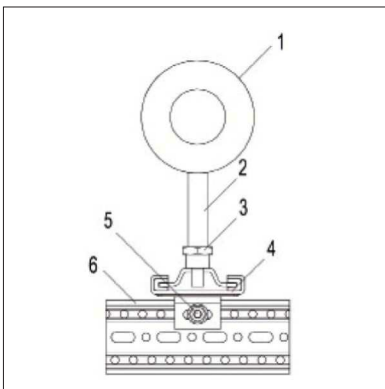

Installation

The installation of Sikla Assembly Groups should be done simultaneously with the line mounting on site.

Parts list

- Pos. 1 Pipe Clamp Stabil D-3G m.E.
- Pos. 2 Threaded Tube G 1/2"
- Pos. 3 Hexagon Nut NT G 1/2"
- Pos. 4 Slide Set GS F80 1G
- Pos. 5 Self Forming Screw FLS F
- Pos. 6 Beam Section TP F80

Technical Data

Maximum height $L_{max} = 200 \text{ mm}$

Material

Plate components: Steel, hcp
 Screws and nuts: Steel, hcp
 Clamp material: Steel, electro-galvanised
 Insulation insert: PUR-foam (250 kg/m³, B2), $\mu = 1200$,
 $\lambda = 0,045 \text{ W/mK bei } (0^\circ\text{C})$
 Temperature range: $-50^\circ\text{C bis } +105^\circ\text{C}$

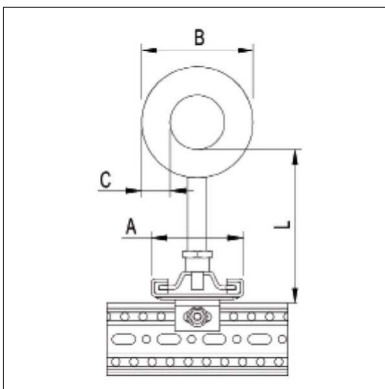

Type	nominal width [DN]	A [mm]	B [mm]	C [mm]	W [kg]	Quantity [Pack]	Part number
21/30	15	102	81	30	1,88	1	110299
27/30	20	102	87	30	1,88	1	110300
33/30	25	102	93	30	1,89	1	110301
42/30	32	102	102	30	1,90	1	110302
48/30	40	102	108	30	1,90	1	110303
60/30	50	102	120	30	1,99	1	110304
76/30	65	102	136	30	2,11	1	110305
89/30	80	102	149	30	2,16	1	110306
114/40	100	102	195	40	2,74	1	110307

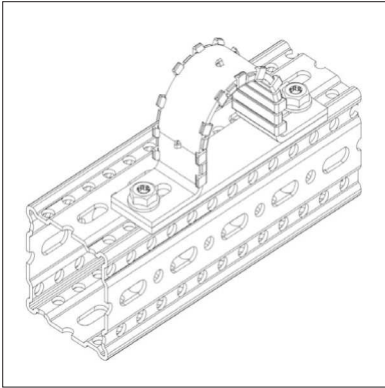

Assembly Group BG52 F80/100

Application

Assembly Group for uninsulated pipes as guided pipe installation, without special requirements. The U-Clamp is an alternative to a traditional U-Bolt and designed to be connected directly into the secondary support. The application of the Slide Plate will reduce the impact of friction on the surface of both pipe and support structure. Potential bi-metal corrosion between U-Clamp and pipe, for example by stainless steel pipes, will be avoided by a customised plastic insert which is self-locking with the U-Clamp's mild steel.

Scope of delivery

The parts are delivered sorted and are to be fastened during Assembly.

Installation

The installation of Sikla Assembly Groups should be done simultaneously with the line mounting on site.

Parts list

- Pos. 1 U Clamp RUC I
- Pos. 2 Self Forming Screw FLS F
- Pos. 3 Beam Section TP F80/100

Technical Data

Material

Clamp body: Steel, hcp
 inlay and slide plate: Thermoplastic plastics
 Temperature range: -20°C to +90°C (to insert and slide plate)

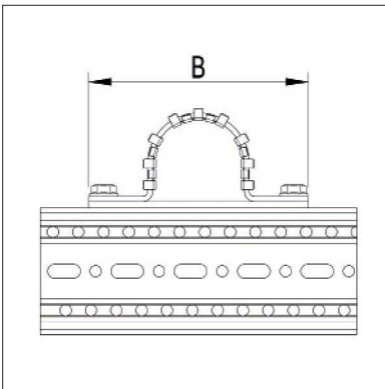
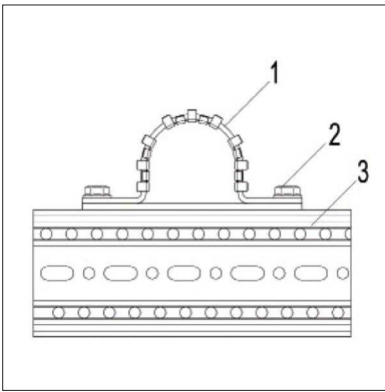

Type	nominal width [DN]	B [mm]	W [kg]	Quantity [pack]	Part number
27	15	134	0,28	1	114656
33	20	140	0,29	1	114657
40	25	147	0,32	1	114658
48	32	155	0,34	1	114659
55	40	161	0,36	1	114660
67	50	173	0,41	1	114661
83	65	189	0,48	1	114662
95	80	202	0,52	1	114663
121	100	227	0,61	1	114664
152	125	259	0,71	1	114665
181	150	287	0,83	1	114666
232	200	338	0,99	1	114667
286	250	392	1,20	1	114668
336	300	443	1,34	1	114669

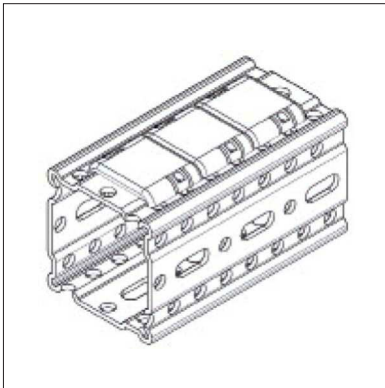

Assembly Group BG51 F80

Application

Assembly Group for uninsulated pipe installation without special requirements. This Assembly Group will allow the pipe free horizontal expansion and contraction on a Beam Section TP F 80.

Scope of delivery

The Pad U-UB F80 are same kind delivered and summed. Each Assembly Group contains are 3 Pads U-UB F80.

Installation

Accordingly expected lateral movement of the supported Pipelines you need 1 up to 3 U-Bolt Fastenings at the Beam.

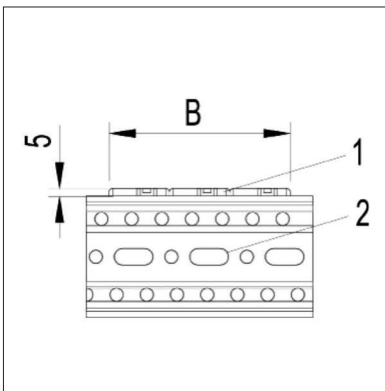

quantity Pad U-UB F80	width B [mm]	width B [in]
1	40	1,57
2	80	3,14
3	120	4,72

Parts list

Pos. 1	Pad U-UB F80
Pos. 2	Beam Section TP F80

Technical Data

Material: polyamide PA 6.0
 Temperature range: -20°C to +130°C

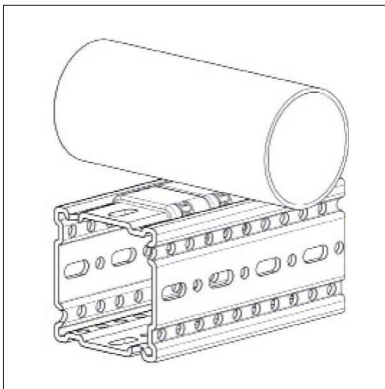

Type	nominal width [NB]	nominal width [NPS]	W [kg]	W [lb]	Quantity [Pack]	Part number
F80	15-150	1/2" - 6"	0,03	0,06	1	112742

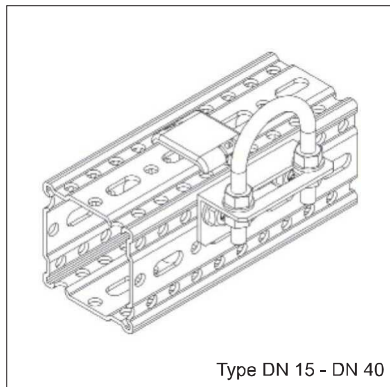

Type DN 15 - DN 40

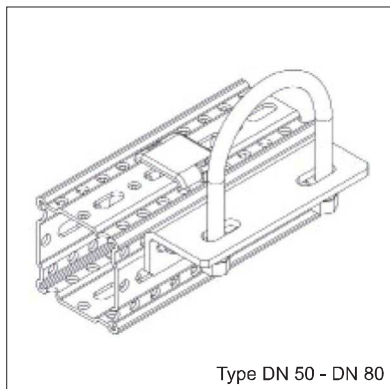

Type DN 50 - DN 80

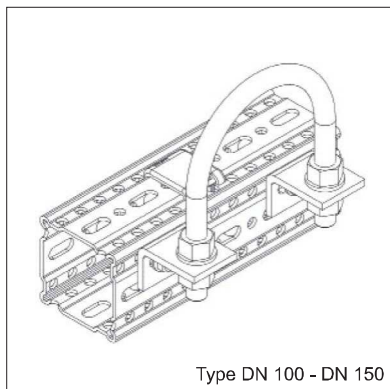

Type DN 100 - DN 150

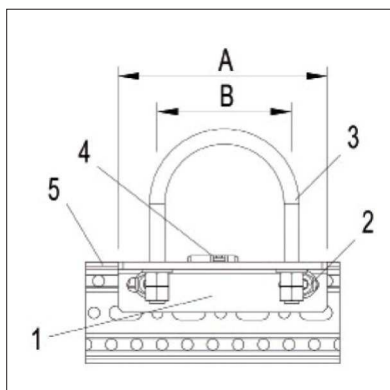

Assembly Group BG22 F80

Application

Assembly Group for uninsulated pipe installation without special requirements. Suitable as pipe guide or fixed point depending on the arrangement of the Hexagon Nuts supplied with it.

Scope of delivery

Sikla components are delivered as accumulated pieces goods assorted and separated for each item. From U Bolt \geq DN100 you always need two U Bolt Fastening UB F.

Installation

The installation of Sikla Assembly Groups should be done simultaneously with the line mounting on site. For Guided Support you need nuts at the U-Bolt which are arranged double-sided up and down. For Fixed Points with fixed Pipe Joints do not exceed maximum permitted load of the connection the bending load of the clamps.

Parts list

- Pos. 1 U Bolt Fastening UB F
- Pos. 2 Self Forming Screw FLS F
- Pos. 3 U Bolt RUB
- Pos. 4 Pad U-UB F80
- Pos. 5 Beam Section TP F80

Technical Data

Material

Plate components: Steel, hcp
 Screws and nuts: Steel, hcp
 Pad U-UB: polyamide, PA 6.0

Type	pipe Outside \varnothing [mm]	A [mm]	B [mm]	B [in]	W [kg]	W [lb]	Quantity [pack]	Part number
DN15	21,3	85	30	1.18	0,28	0,61	1	110236
DN20	26,9	85	40	1.57	0,32	0,70	1	110237
DN25	33,7	85	48	1.88	0,32	0,70	1	110238
DN32	42,4	85	56	2.20	0,34	0,75	1	110239
DN40	48,3	85	62	2.44	0,34	0,75	1	110240
DN50	60,3	146	76	2.99	0,94	2,07	1	110241
DN65	76,1	146	94	3.70	0,97	2,13	1	110242
DN80	88,9	146	106	4.17	1,00	2,20	1	110243
DN100	114,3	181	136	5.35	1,06	2,33	1	110244
DN125	139,7	209	164	6.46	1,14	2,51	1	110245
DN150	168,3	237	192	7.56	1,23	2,71	1	110246

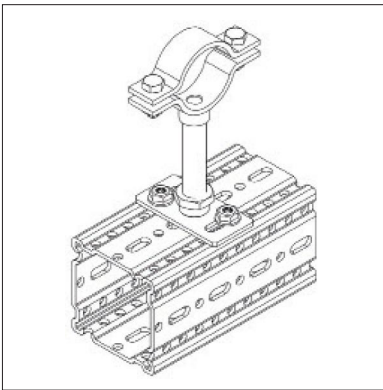

Assembly Group BG16 F100-1/2"

Application

Assembly Group for a fixed pipe connection based on medium-duty Pipe Clamp Stabil I-1/2", suitable for industrial requirements. The secondary steel interface is designed to easily connect the Assembly Group to a Beam Section TP F 100 by using Self Forming Screws FLS F. Height-adjustability is available via the 1/2" Threaded Tube.

Scope of delivery

Sikla components are delivered as accumulated pieces goods assorted and separated for each item. The Threaded Tube is supplied by the meter (2m Tubes) and has to be cut to length on site.

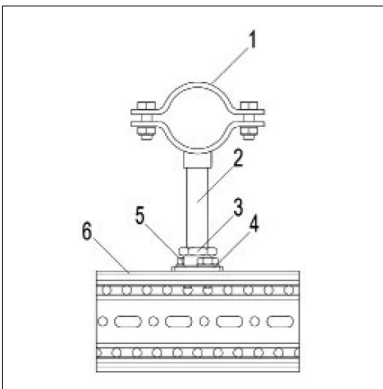

Installation

The installation of Sikla Assembly Groups should be done simultaneously with the line mounting on site.

Part list

- Pos. 1 Pipe Clamp Stabil I-1/2"
- Pos. 2 Threaded Tube GR 2m 1/2"
- Pos. 3 Locking Nut NT G 1/2"
- Pos. 4 Mounting Plate GPL F100-1/2"
- Pos. 5 Self Forming Screw FLS F
- Pos. 6 Beam Section TP F100

Technical Data

Maximum height $L_{max} = 300$ mm
 Maximum height L_{max} horizontal = 150 mm

Material

Plate components: Steel, hcp
 Screws and nuts: Steel, hcp

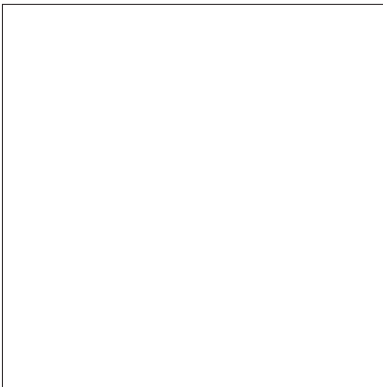

Type	Clamping range [mm]	A [mm]	B [mm]	W [kg]	Quantity [Pack]	Part number
DN15	16-22	50	85	0,85	1	113842
DN20	23-27	50	92	0,88	1	113843
DN25	30-34	50	100	0,91	1	113844
DN32	39-44	50	112	0,95	1	113845
DN40	44-49	50	117	0,97	1	113846
DN50	57-61	50	139	1,19	1	113847
DN65	73-77	50	156	1,27	1	113848
DN80	85-89	50	168	1,33	1	113849
DN100	109-116	50	194	1,62	1	113850

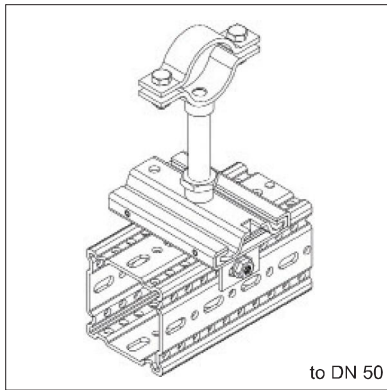

to DN 50

Assembly Group BG17 F100-1/2"

Application

Assembly Group for a guided pipe connection based on medium-duty pipe clamp Stabil I-1/2", suitable for industrial requirements. The secondary steel interface is designed to easily connect the Assembly Group to a Beam Section TP F 100 by using Self Forming Screws FLS F. Height-adjustability is available via the 1/2" Threaded Tube.

Scope of delivery

Sikla components are delivered as accumulated pieces goods assorted and separated for each item. The Threaded Tube is supplied by the meter (2m Tubes) and has to be cut to length on site.

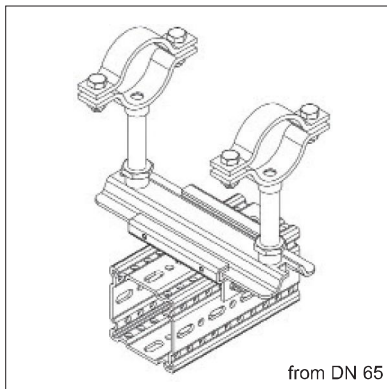

from DN 65

Installation

The installation of Sikla Assembly Groups should be done simultaneously with the line mounting on site.

Part list

- Pos. 1 Pipe Clamp Stabil I-1/2"
- Pos. 2 Threaded Tube GR 2m 1/2"
- Pos. 3 Locking Nut NT G 1/2"
- Pos. 4 Slide Set GS F100 1G/Slide Set GS F100 1G2
- Pos. 5 Self Forming Screw FLS F
- Pos. 6 Beam Section TP F100

Technical Data

Maximum height $L_{max} = 200$ mm

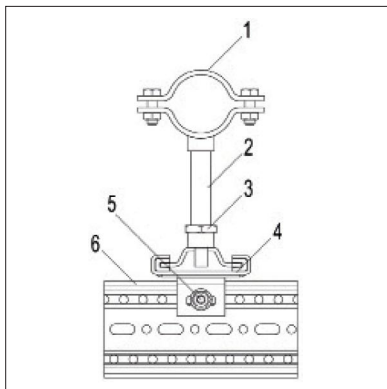

Material

Plate components: Steel, hcp
Screws and nuts: Steel, hcp

Type	Clamping range [mm]	A [mm]	B [mm]	W [kg]	Quantity [Pack]	Part number
DN15	16-22	102	85	2,00	1	113851
DN20	23-27	102	92	2,01	1	113852
DN25	30-34	102	100	2,04	1	113853
DN32	39-44	102	112	2,08	1	113854
DN40	44-49	102	117	2,10	1	113855
DN50	57-61	102	139	2,32	1	113856
DN65	73-77	102	156	3,76	1	113857
DN80	85-89	102	168	3,88	1	113858
DN100	109-116	102	194	4,46	1	113859

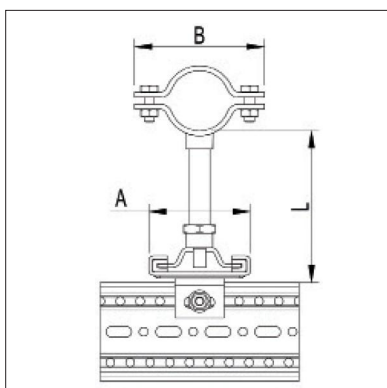

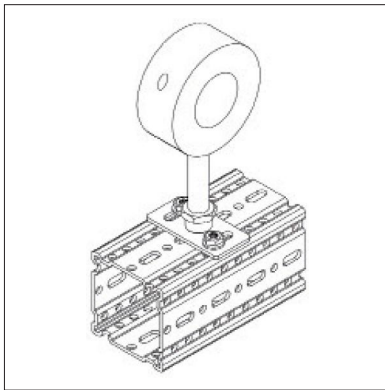

Assembly Group BG49 F100-1/2"

Application

Assembly Group as fixed connection based on an insulated Chilled Water Clamp RB, suitable for industrial chilled water systems.

The secondary steel interface is designed to easily connect the Assembly Group to a Beam Section TP F 100 by using Self Forming Screws FLS F. Height-adjustability is available via the 1/2" Threaded Tube.

Scope of delivery

Sikla components are delivered as accumulated pieces goods assorted and separated for each item. The Threaded Tube is supplied by the meter (2m Tubes) and has to be cut to length on site.

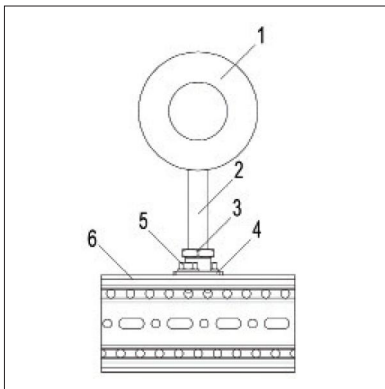

Installation

The installation of Sikla Assembly Groups should be done simultaneously with the line mounting on site. Construction group for creating light clamp connections for Sikla siFramo 100 System. The height can be adjusted over the Threaded Tube 1/2". Insulated pipe clamp out PUR-rigid foam for refrigeration and cold water systems.

Parts list

- Pos. 1 Chilled Water Clamp RB
- Pos. 2 Threaded Tube GR 2m 1/2"
- Pos. 3 Locking Nut NT G 1/2"
- Pos. 4 Mounting Plate GPL F100-1/2"
- Pos. 5 Self Forming Screw FLS F
- Pos. 6 Beam Section TP F100

Technical Data

Maximum height $L_{max} = 300$ mm
 Maximum height L_{max} horizontal = 150 mm

Material

Plate components: Steel, hcp
 Screws and nuts: Steel, hcp
 insulation insert: PUR-foam(250 kg/m³, B2), $\mu = 1200$,
 $\lambda = 0,045$ W/mK bei (0°C)
 Temperature range: -50°C bis +105°C

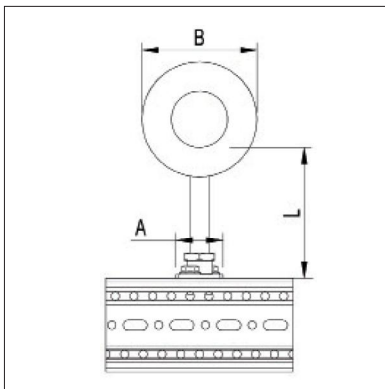

Type	Clamping range [DN]	A [mm]	B [mm]	C [mm]	W [kg]	Quantity [Pack]	Part number
21/30	15	50	81	30	0,77	1	113860
27/30	20	50	87	30	0,77	1	113861
33/30	25	50	93	30	0,78	1	113862
42/30	32	50	102	30	0,79	1	113863
48/30	40	50	108	30	0,79	1	113864
60/30	50	50	120	30	0,88	1	113865
76/30	65	50	136	30	1,00	1	113866
89/30	80	50	149	30	1,05	1	113867
114/40	100	50	195	40	1,63	1	113868

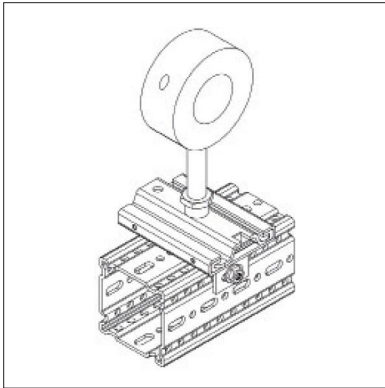

Assembly Group BG50 F100-1/2"

Application

Assembly Group as guided connection based on an insulated Chilled Water Clamp RB, suitable for industrial chilled water systems.

The secondary steel interface is designed to easily connect the Assembly Group to a Beam Section TP F 100 by using Self Forming Screws FLS F. Height-adjustability is available via the 1/2" Threaded Tube.

Scope of delivery

The parts are delivered total sorted and separate for individual components. The Threaded Tube is supplied by the meter (2m Tubes) and is cut to length on site.

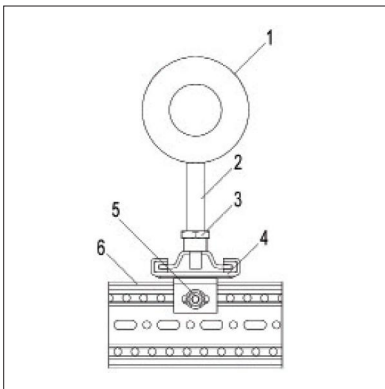

Installation

The installation of Sikla Assembly Groups should be done simultaneously with the line mounting on site. Construction group for creating light clamp connections for Sikla siFramo 100 System. The height can be adjusted over the Threaded Tube 1/2". Insulated pipe clamp out PUR-rigid foam for refrigeration and cold water systems.

Parts list

- Pos. 1 Chilled Water Clamp RB
- Pos. 2 Threaded Tube GR 2m 1/2"
- Pos. 3 Locking Nut NT G 1/2"
- Pos. 4 Slide Set GS F100 1G
- Pos. 5 Self Forming Screw FLS F
- Pos. 6 Beam Section TP F100

Technical Data

Maximum height $L_{max} = 200 \text{ mm}$

Material

Plate components: Steel, hcp
 Screws and nuts: Steel, hcp
 insulation insert: PUR-foam(250 kg/m³, B2), $\mu = 1200$,
 $\lambda = 0,045 \text{ W/mK}$ bei (0°C)
 Temperature range: -50°C bis +105°C

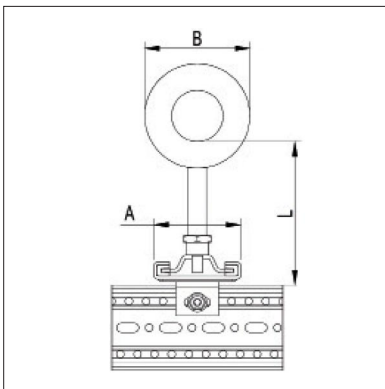

Type	Clamping range [DN]	A [mm]	B [mm]	C [mm]	W [kg]	Quantity [Pack]	Part number
21/30	15	102	81	30	1,90	1	113869
27/30	20	102	87	30	1,90	1	113870
33/30	25	102	93	30	1,91	1	113871
42/30	32	102	102	30	1,92	1	113872
48/30	40	102	108	30	1,92	1	113873
60/30	50	102	120	30	2,01	1	113874
76/30	65	102	136	30	2,13	1	113875
89/30	80	102	149	30	2,18	1	113876
114/40	100	102	195	40	2,76	1	113877

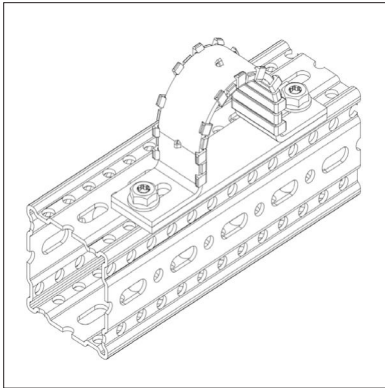

Assembly Group BG52 F80/100

Application

Assembly Group for uninsulated pipes as guided pipe installation, without special requirements. The U-Clamp is an alternative to a traditional U-Bolt and designed to be connected directly into the secondary support. The application of the Slide Plate will reduce the impact of friction on the surface of both pipe and support structure. Potential bi-metal corrosion between U-Clamp and pipe, for example by stainless steel pipes, will be avoided by a customised plastic insert which is self-locking with the U-Clamp's mild steel.

Scope of delivery

The parts are delivered sorted and are to be fastened during Assembly.

Installation

The installation of Sikla Assembly Groups should be done simultaneously with the line mounting on site.

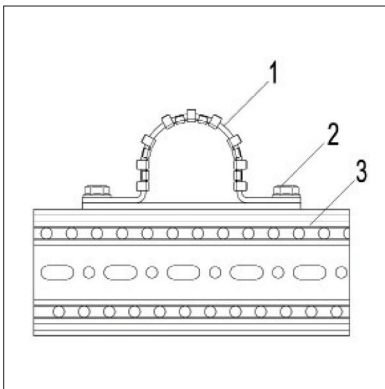

Parts list

- Pos. 1 U Clamp RUC I
- Pos. 2 Self Forming Screw FLS F
- Pos. 3 Beam Section TP F80/100

Technical Data

Material

Clamp body: Steel, hcp
 inlay and slide plate: Thermoplastic plastics
 Temperature range: -20°C to +90°C (to insert and slide plate)

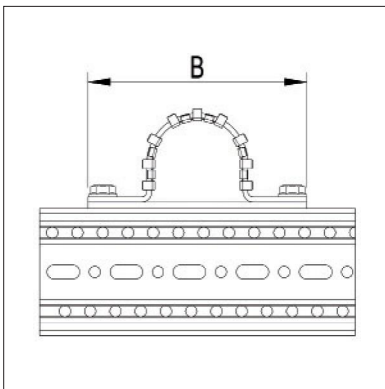

Type	nominal width [DN]	B [mm]	W [kg]	Quantity [pack]	Part number
27	15	134	0,28	1	114656
33	20	140	0,29	1	114657
40	25	147	0,32	1	114658
48	32	155	0,34	1	114659
55	40	161	0,36	1	114660
67	50	173	0,41	1	114661
83	65	189	0,48	1	114662
95	80	202	0,52	1	114663
121	100	227	0,61	1	114664
152	125	259	0,71	1	114665
181	150	287	0,83	1	114666
232	200	338	0,99	1	114667
286	250	392	1,20	1	114668
336	300	443	1,34	1	114669

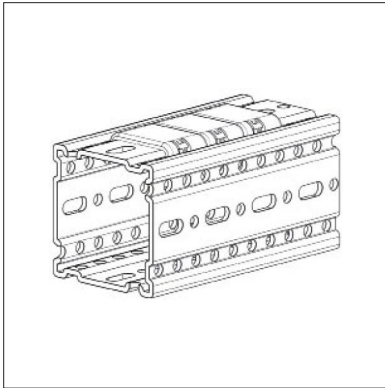

Assembly Group BG54 F100

Application

Assembly Group for uninsulated pipe skid installation without special requirements. This Assembly Group allow the pipe free horizontal expansion and contraction on a Beam Section TP F100.

Scope of delivery

The Pad U-UB F100 are same kind delivered and summed. Each Assembly Group contains are 3 Pads U-UB F100.

Installation

Correspondingly of the expected lateral movement of the on lying pipeline are 1 to 3 Pad U-UB F100 in the Beam Section to click.

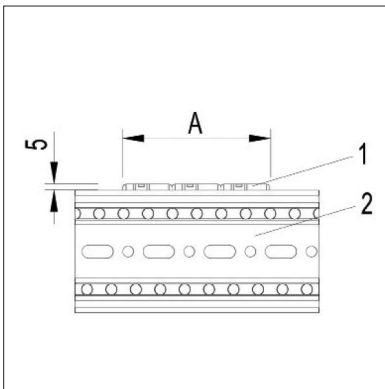

quantity Pad U-UB F80	width B [mm]	width B [in]
1	40	1,57
2	80	3,14
3	120	4,72

Parts list

Pos. 1 Pad U-UB F100
Pos. 2 Beam Section TP F100

Technical Data

Material: polyamide PA 6.0
Temperature range: -20°C to +130°C

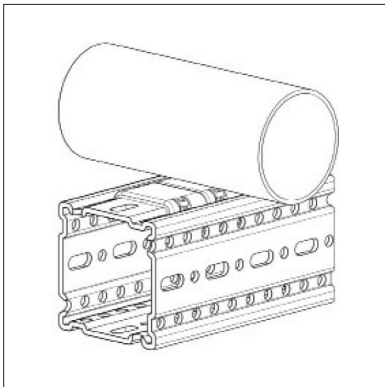

Type	nominal width [DN]	nominal width [NPS]	W [kg]	W [lb]	Quantity [pack]	Part number
F100	15-300	1/2" - 12"	0,03	0,06	1	113913

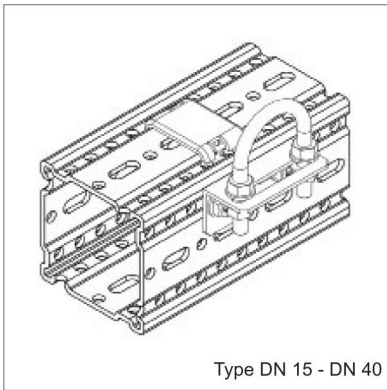

Type DN 15 - DN 40

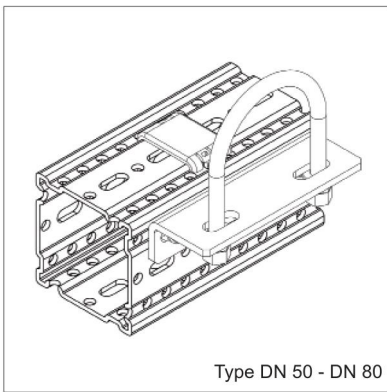

Type DN 50 - DN 80

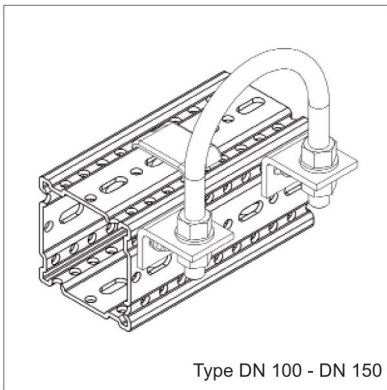

Type DN 100 - DN 150

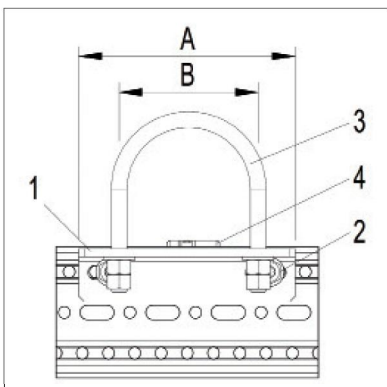

Assembly Group BG22 F100

Application

Assembly Group for uninsulated pipe installation without special requirements. Suitable as pipe guide or fixed point depending on the arrangement of the Hexagon Nuts supplied with it.

Scope of delivery

Sikla components are delivered as accumulated pieces goods assorted and separated for each item. From U Bolt \geq DN100 you always need to use two U Bolt Fastening UB F.

Installation

The installation of Sikla Assembly Groups should be done simultaneously with the line mounting on site. For Guided Support you need nuts at the U-Bolt which are arranged double-sided up and down. For Fixed Points with fixed Pipe Joints do not exceed maximum permitted load of the connection the bending load of the clamps.

Parts list

- Pos. 1 U Bolt Fastening UB F
- Pos. 2 Self Forming Screw FLS F
- Pos. 3 U Bolt RUB
- Pos. 4 Pad U-UB F100
- Pos. 5 Beam Section TP F100

Technical Data

Material

Plate components: Steel, hcp
Screws and nuts: Steel, hcp
Pad U-UB: polyamide, PA 6.0

Type	pipe Outside \varnothing [mm]	A [mm]	B [mm]	W [kg]	Quantity [Pack]	Part number
DN15	21,3	85	30	0,28	1	113977
DN20	26,9	85	40	0,32	1	113978
DN25	33,7	85	48	0,32	1	113979
DN32	42,4	85	56	0,34	1	113980
DN40	48,3	85	62	0,34	1	113981
DN50	60,3	146	76	0,94	1	113982
DN65	76,1	146	94	0,97	1	113983
DN80	88,9	146	106	1,00	1	113984
DN100	114,3	181	136	1,06	1	113985
DN125	139,7	209	164	1,14	1	113986
DN150	168,3	237	192	1,23	1	113987

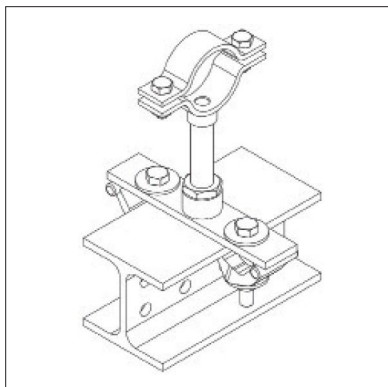

Assembly Group BG60 T100-1/2"

Application

Assembly Group for a fixed pipe connection based on medium-duty Pipe Clamp Stabil I-1/2", suitable for industrial requirements. The secondary steel interface is designed to easily connect the Sikla Structural Elements 100 and all steel beams with a flange width of 100 mm. Height-adjustability is available via the 1/2" Threaded Tube.

Scope of delivery

Sikla components are delivered as accumulated pieces goods assorted and separated for each item. Threaded Tube is supplied by the meter (2m Tubes) and has to be cut to length on site.

Installation

The installation of Sikla Assembly Groups should be done simultaneously with the line mounting on site.

Part list

- Pos. 1 Pipe Clamp Stabil I-1/2"
- Pos. 2 Threaded Tube GR 2m 1/2"
- Pos. 3 Locking Nut NT G 1/2"
- Pos. 4 Mounting Plate GPL Stabil R 1/2"-100
- Pos. 5 Assembly Set P2/2 S
- Pos. 6 Beam Section TP F100

Technical Data

Maximum height $L_{max} = 300$ mm
 Maximum height $L_{max\ horizontal} = 150$ mm

Material

Plate components: Steel, hcp
 Screws and nuts: Steel, hcp

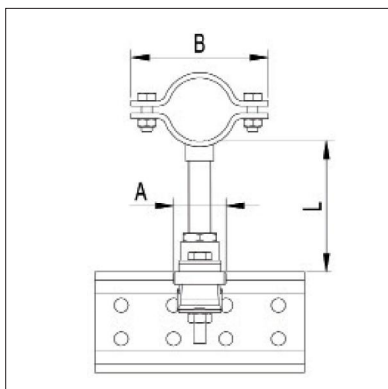
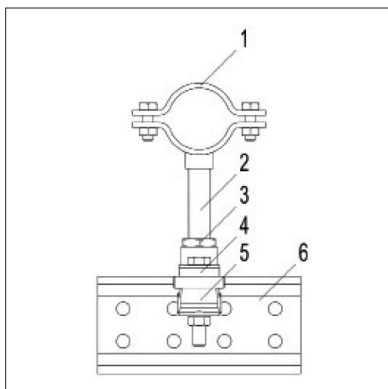

Type	Clamp range [mm]	A [mm]	B [mm]	W [kg]	Quantity [Pack]	Part number
DN15	16-22	50	85	1,75	1	112724
DN20	23-27	50	92	1,76	1	112725
DN25	30-34	50	100	1,79	1	112726
DN32	39-44	50	112	1,83	1	112727
DN40	44-49	50	117	1,85	1	112728
DN50	57-61	50	139	2,07	1	112729
DN65	73-77	50	156	2,15	1	112730
DN80	85-89	50	168	2,21	1	112731
DN100	109-116	50	194	2,50	1	112732

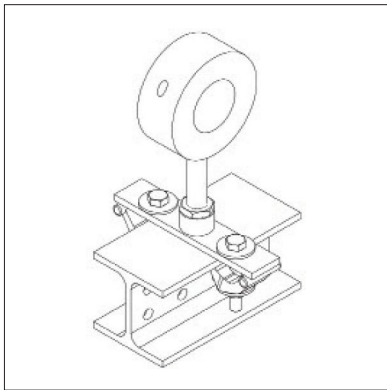

Assembly Group BG61 T100-1/2"

Application

Assembly Group for a fixed pipe connection based on an insulated Chilled Water Clamp RB, suitable for industrial requirements. The secondary steel interface is designed to easily connect the Sikla Structural Elements 100 and all steel beams with a flange width of 100 mm. Height-adjustability is available via the 1/2" Threaded Tube.

Scope of delivery

Sikla components are delivered as accumulated pieces goods assorted and separated for each item. Threaded Tube is supplied by the meter (2m Tubes) and has to be cut to length on site.

Installation

The installation of the individual components of an Assembly has to be done in the course of the pipe construction at site.

Part list

- Pos. 1 Chilled Water Clamp RB
- Pos. 2 Threaded Tube GR 2m 1/2"
- Pos. 3 Locking Nut NT G 1/2"
- Pos. 4 Mounting Plate GPL F100-1/2"
- Pos. 5 Assembly Set P2/2 S
- Pos. 6 Beam Section TP F100

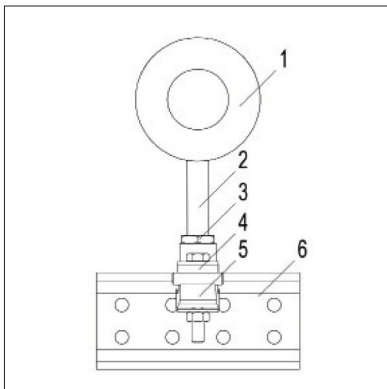

Technical Data

Maximum height $L_{max} = 300$ mm
 Maximum height $L_{max\ horizontal} = 150$ mm

Material

Plate components: Steel, hcp
 Screws and nuts: Steel, hcp
 Insulation insert: PUR-foam (250 kg/m^3 , B2), $\mu = 1200$,
 $\lambda = 0,045\text{ W/mK}$ bei (0°C)
 Temperature range: -50°C bis $+105^\circ\text{C}$

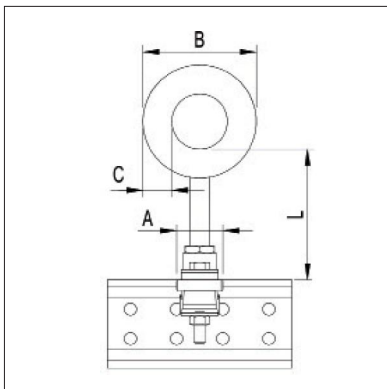

Type	nominal with [DN]	A [mm]	B [mm]	C [mm]	W [kg]	Quantity [Pack]	Part number
21/30	15	50	81	30	1,65	1	112733
27/30	20	50	87	30	1,65	1	112734
33/30	25	50	93	30	1,66	1	112735
42/30	32	50	102	30	1,67	1	112736
48/30	40	50	108	30	1,67	1	112737
60/30	50	50	120	30	1,76	1	112738
76/30	65	50	136	30	1,88	1	112739
89/30	80	50	149	30	1,93	1	112740
114/40	100	50	195	40	2,51	1	112741

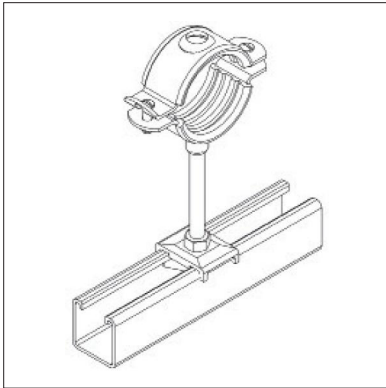

Assembly Group BG11 MS41-M10

Application

Assembly Group as fixed pipe connection based on light-duty Pipe Clamp Stabil D3G, suitable for industrial requirements. The secondary steel interface is designed to easily connect the Assembly Group to the Sikla Channel MS 41. Height-adjustability is available via the M10 stud. Pipe clamps are lined to meet sound-absorption requirements as per EN DIN 4109.

Scope of delivery

Sikla components are delivered as accumulated pieces goods assorted and separated for each item. Threaded Rod is supplied by the meter (1m Rods) and has to be cut to length on site.

Installation

The installation of Sikla Assembly Groups should be done simultaneously with the line mounting on site.

Parts list

- Pos. 1 Pipe Clamp Stabil D-3G m.E.
- Pos. 2 Threaded Rod GST M10x1000
- Pos. 3 Hexagon Nut M10
- Pos. 4 Holding Bracket HK 41/10
- Pos. 5 Channel Nut NT HZ 41
- Pos. 6 Channel MS (D) 41/41/2.5

Technical Data

Maximum height $L_{max} = 150 \text{ mm}$

Material

Plate components: Steel, hcp
 Screws and nuts: Steel, hcp
 Sound Absorbing Elements: SBR/EPDM, black (rubber profile see chapter Sound Absorption Products), captive glued in

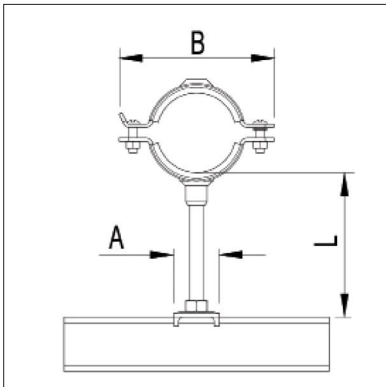
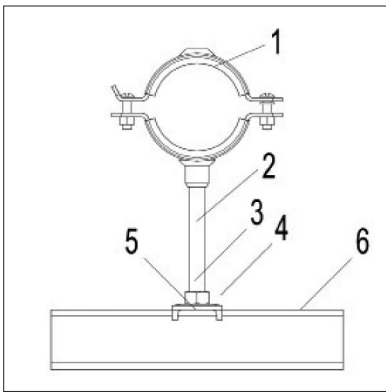

Type	Clamping range [mm]	A [mm]	B [mm]	W [kg]	Quantity [Pack]	Part number
DN15	19-23	35	68	0,27	1	110144
DN20	24-28	35	75	0,30	1	110145
DN25	33-37	35	81	0,32	1	110146
DN32	40-45	35	93	0,34	1	110147
DN40	47-52	35	104	0,36	1	110148
DN50	60-65	35	117	0,38	1	110149
DN65	73-78	35	150	0,48	1	110150
DN80	88-93	35	164	0,53	1	110151
DN100	108-115	35	187	0,59	1	110152

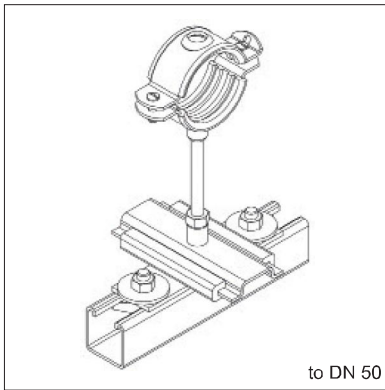

Assembly Group BG13 MS41-M10

Application

Assembly Group as guided pipe connection based on light-duty Pipe Clamp Stabil D3G, suitable for industrial requirements. The secondary steel interface is designed to easily connect the Assembly Group to the Sikla Channel MS 41. Height-adjustability is available via the M10 stud. Pipe clamps are lined to meet sound-absorption requirements as per EN DIN 4109.

Scope of delivery

Sikla components are delivered as accumulated pieces goods assorted and separated for each item. Threaded Rod is supplied by the meter (1m Rods) and has to be cut to length on site.

Installation

The installation of Sikla Assembly Groups should be done simultaneously with the line mounting on site.

Parts list

- Pos. 1 Pipe Clamp Stabil D-3G m.E.
- Pos. 2 Threaded Rod GST M10x1000
- Pos. 3 Hexagon Nut NT M10
- Pos. 4 Slide Set GS 2G-PL / Slide Set GS F80 2G2-PL
- Pos. 5 T-Head Bolt TBO HZ41 M10x20
- Pos. 6 Channel MS (D) 41/41/2.5

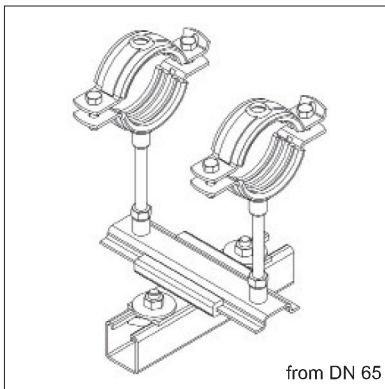

Technical Data

Maximum height Lmax = 150 mm

Material

Plate components: Steel, hcp
 Screws and nuts: Steel, hcp
 Sound Absorbing Elements: SBR/EPDM, black (rubber profile see chapter Sound Absorption Products), captive glued in

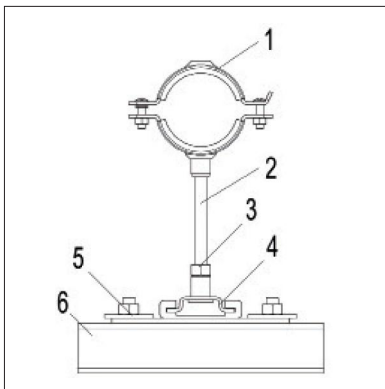

Type	Clampin range [mm]	A [mm]	B [mm]	W [kg]	Quantity [pack]	Nr.
DN15	19-23	140	68	0,90	1	110180
DN20	24-28	140	75	0,93	1	110182
DN25	33-37	140	81	0,95	1	110183
DN32	40-45	140	93	0,97	1	110184
DN40	47-52	140	104	0,99	1	110185
DN50	60-65	140	117	1,01	1	110186
DN65	73-78	140	150	1,62	1	110187
DN80	88-93	140	164	1,72	1	110188
DN100	108-115	140	187	1,84	1	110189

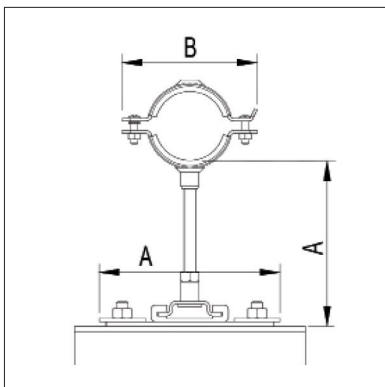

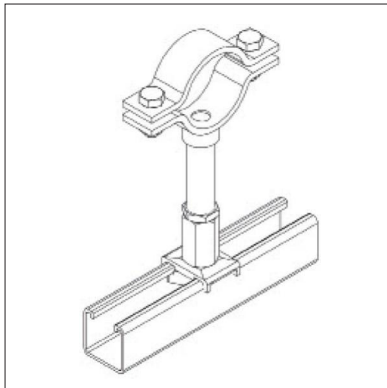

Assembly Group BG11 MS41-1/2"

Application

Assembly Group as fixed pipe connection based on medium-duty Pipe Clamp Stabil I-1/2", suitable for industrial requirements. The secondary steel interface is designed to easily connect the Sikla Channel MS 41. Height-adjustability is available via the 1/2" Threaded Tube.

Scope of delivery

Sikla components are delivered as accumulated pieces goods assorted and separated for each item. Threaded Tube is supplied by the meter (2m Tubes) and has to be cut to length on site.

Installation

The installation of Sikla Assembly Groups should be done simultaneously with the line mounting on site.

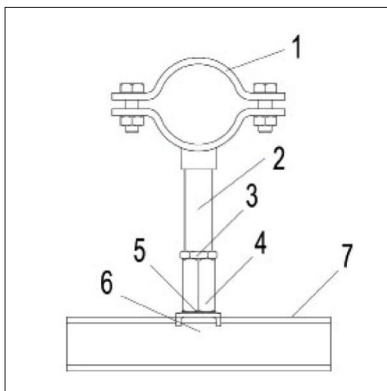

Parts list

- Pos. 1 Pipe Clamp Stabil I-1/2"
- Pos. 2 Threaded Tube GR 2m 1/2"
- Pos. 3 Locking Nut NT G 1/2"
- Pos. 4 Adapter AD IG/IG 1/2"/M16
- Pos. 5 Holding Bracket HK 41/16
- Pos. 6 T-Head Bolt TBO HZ41 M16x25
- Pos. 7 Channel MS (D) 41/41/2.5

Technical Data

Maximum height $L_{max} = 300$ mm
 Maximum height $L_{max \text{ horizontal}} = 150$ mm

Material

Plate components: Steel, hcp
 Screws and nuts: Steel, hcp

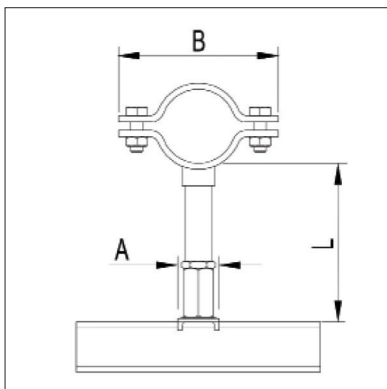

Type	Clamp range [mm]	A [mm]	B [mm]	W [kg]	Quantity [Pack]	Part number
DN15	16-22	35	85	0,92	1	110153
DN20	23-27	35	92	0,93	1	110154
DN25	30-34	35	100	0,96	1	110155
DN32	39-44	35	112	1,04	1	110156
DN40	44-49	35	117	1,02	1	110157
DN50	57-61	35	139	1,24	1	110158
DN65	73-77	35	156	1,32	1	110159
DN80	85-89	35	168	1,38	1	110160
DN100	109-116	35	194	1,67	1	110161

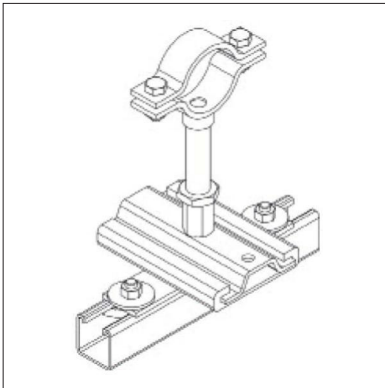

Assembly Group BG13 MS41-1/2"

Application

Assembly Group for a guided pipe connection based on medium-duty Pipe Clamp Stabil I-1/2", suitable for industrial requirements. The secondary steel interface is designed to easily connect the Sikla Channel MS 41. Height-adjustability is available via the 1/2" Threaded Tube.

Scope of delivery

Sikla components are delivered as accumulated pieces goods assorted and separated for each item. Threaded Tube is supplied by the meter (2m Tubes) and has to be cut to length on site.

Installation

The installation of Sikla Assembly Groups should be done simultaneously with the line mounting on site.

Parts list

- Pos. 1 Pipe Clamp Stabil I-1/2"
- Pos. 2 Threaded Tube GR 2m 1/2"
- Pos. 3 Locking Nut NT G 1/2"
- Pos. 4 Adapter AD IG/IG 1/2"/1/2"
- Pos. 5 Slide Set GSH3G-PL/ Slide Set GS H3G2-PL
- Pos. 6 T-Head Bolt TBO HZ41 M10x20
- Pos. 7 Channel MS (D) 41/41/2.5

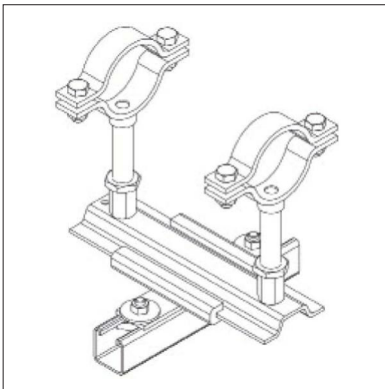

Technical Data

Maximum height $L_{max} = 200$ mm

Material

Plate components: Steel, hcp
Screws and nuts: Steel, hcp

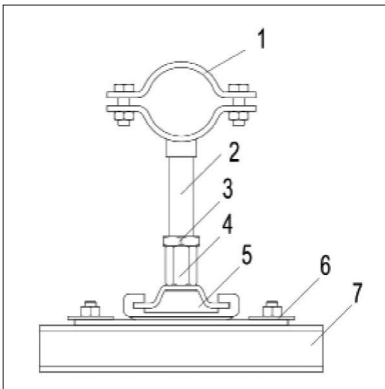

Type	Clamping range [mm]	A [mm]	B [mm]	W [kg]	Quantity [Pack]	Part number
DN15	16-22	190	85	2,17	1	110191
DN20	23-27	190	92	2,18	1	110192
DN25	30-34	190	100	2,21	1	110193
DN32	39-44	190	112	2,29	1	110194
DN40	44-49	190	117	2,27	1	110195
DN50	57-61	190	139	2,49	1	110196
DN65	73-77	190	156	3,97	1	110197
DN80	85-89	190	168	4,09	1	110198
DN100	109-116	190	194	4,67	1	110199

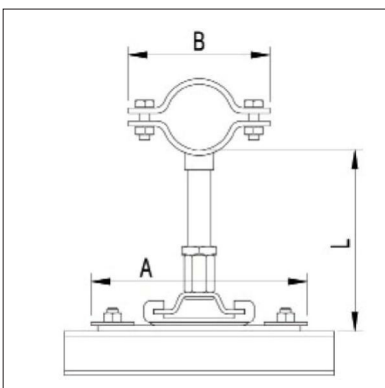

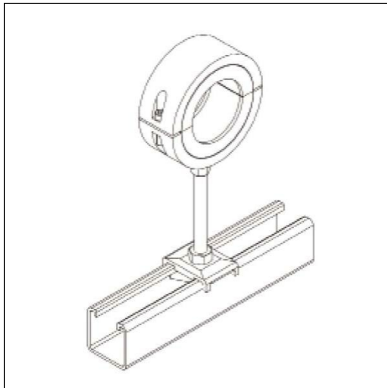

Assembly Group BG47 MS41-M10

Application

Assembly Group for a fixed pipe connection based on an insulated Chilled Water Clamp KSH, suitable for industrial chilled water systems.

The secondary steel interface is designed to easily connect the Assembly Group to Sikla Channel MS 41. Height-adjustability is available via the M10 stud.

Scope of delivery

The parts are delivered total sorted and separate for individual components. The Threaded Rod is supplied by the meter (1m Rods) and is cut to length on site.

Installation

The installation of Sikla Assembly Groups should be done simultaneously with the line mounting on site.

Parts list

- Pos. 1 Chilled Water Clamp KSH
- Pos. 2 Threaded Rod GST M10x1000
- Pos. 3 Hexagon Nut NT M10
- Pos. 4 Holding Bracket HK 41/10
- Pos. 5 Channel Nut NT HZ41-M10
- Pos. 6 Channel MS (D) 41/41/2.5

Technical Data

Maximum height Lmax = 150 mm

Material

- Plate components: Steel, hcp
- Screws and nuts: Steel, hcp
- Clamp material: Steel, electro-galvanised
- Insulation insert: PUR-foam (250 kg/m³, B2), λ = 0,042 W/mK (0°C), Impermeable diffusion resistance closed-cell caoutchouc, B1
- Fire resistance: closed-cell polyurethane foam, B1
- Sound Absorption Elements: closed-cell polyurethane foam, B1
- Temperature range: -40°C bis +105°C

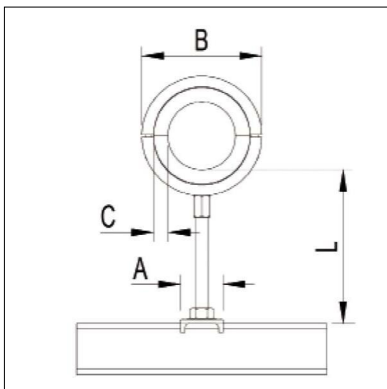
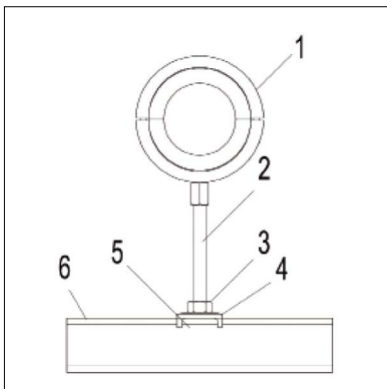

Type	nominal width [DN]	A [mm]	B [mm]	C [mm]	W [kg]	Quantity [Pack]	Part number
KSH 21	15	35	55	13	0,28	1	113898
KSH 27	20	35	63	14	0,29	1	113899
KSH 33	25	35	70	14	0,30	1	113900
KSH 42	32	35	84	15	0,33	1	113901
KSH 48	40	35	84	15	0,33	1	113902
KSH 60	50	35	96	15	0,35	1	113903

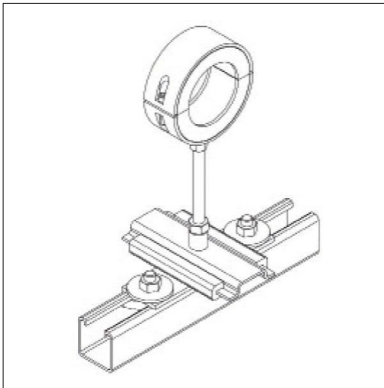

Assembly Group BG42 MS41-M10

Application

Assembly Group a fixed pipe connection based on Chilled Water Clamp RB for Refrigeration and chilled water system, suitable for industrial requirements. The secondary steel interface is designed to easily connect the Sikla Channel MS 41. Height-adjustability is available via the M10 stud.

Scope of delivery

Sikla components are delivered as accumulated pieces goods assorted and separated for each item. The Threaded Rod is supplied by the meter (1m Rods) and has to be cut to length on site.

Installation

The installation of Sikla Assembly Groups should be done simultaneously with the line mounting on site.

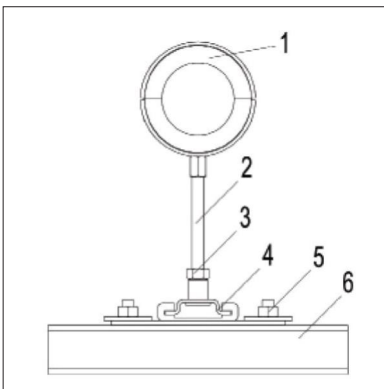

Parts list

- Pos. 1 Chilled Water Clamp KSH
- Pos. 2 Threaded Rod GST M10x1000
- Pos. 3 Hexagon Nut NT M10
- Pos. 4 Slide Set GS 2G-PL
- Pos. 5 T-Head Bolt TBO HZ41 M10x20
- Pos. 6 Channel MS (D) 41/41/2.5

Technical Data

Maximum height $L_{max} = 150 \text{ mm}$

Material

- Plate components: Steel, hcp
- Screws and nuts: Steel, hcp
- Clamp material: Steel, electro-galvanised
- Insulation insert: PUR-foam (250 kg/m³, B2), $\lambda = 0,042 \text{ W/mK (0°C)}$, Impermeable diffusion resistance closed-cell caoutchouc, B1
- Fire resistance: closed-cell polyurethane foam, B1
- Temperature range: -40°C bis +105°C

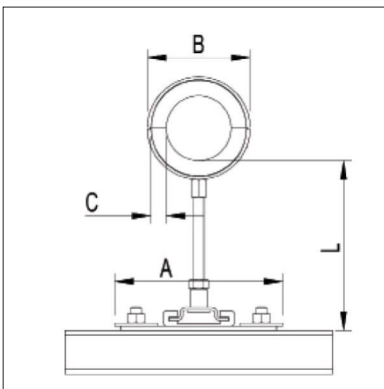

Type	nominal width [DN]	A [mm]	B [mm]	C [mm]	W [kg]	Quantity [Pack]	Part number
KSH 21	15	140	55	13	0,91	1	110262
KSH 27	20	140	63	14	0,92	1	110263
KSH 33	25	140	70	14	0,93	1	110264
KSH 42	32	140	84	15	0,96	1	110265
KSH 48	40	140	84	15	0,96	1	110266
KSH 60	50	140	96	15	0,98	1	110267

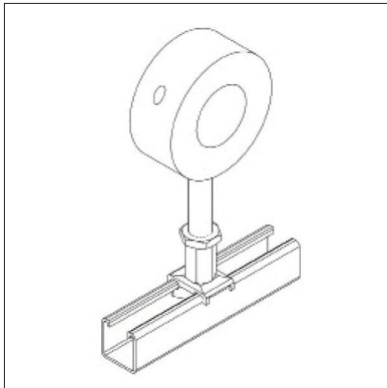

Assembly Group BG48 MS41-1/2"

Application

Assembly Group as fixed connection based on an insulated Chilled Water Clamp RB, suitable for industrial chilled water systems.

The secondary steel interface is designed to easily connect the Assembly Group to Sikla Channel MS 41. Height-adjustability is available via the 1/2" Threaded Tube.

Scope of delivery

Sikla components are delivered as accumulated pieces goods assorted and separated for each item. The Threaded Rod is supplied by the meter (2m Rods) and has to be cut to length on site.

Installation

The installation of Sikla Assembly Groups should be done simultaneously with the line mounting on site.

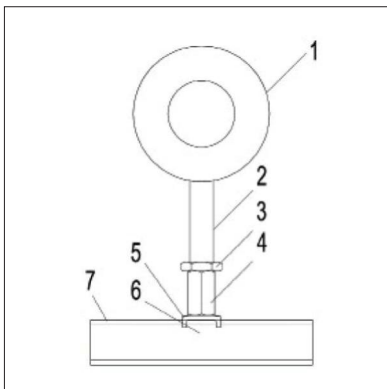

Parts list

- Pos. 1 Chilled Water Clamp RB
- Pos. 2 Threaded Tube GR 2m 1/2"
- Pos. 3 Locking Nut NT G 1/2"
- Pos. 4 Adapter AD IG/IG 1/2"/M16
- Pos. 5 Holding Bracket HK 41/16
- Pos. 6 T-Head Bolt TBO HZ41 M16x25
- Pos. 7 Channel MS (D) 41/41/2.5

Technical Data

Maximum height $L_{max} = 200$ mm

Material

Plate components: Steel, hcp
 Screws and nuts: Steel, hcp
 Clamp material: Steel, electro-galvanised
 Insulation insert: PUR-foam (250 kg/m³, B2), $\mu=1200$, $\lambda = 0,045$ W/mK (0°C)
 Temperature range: -40°C bis +105°C

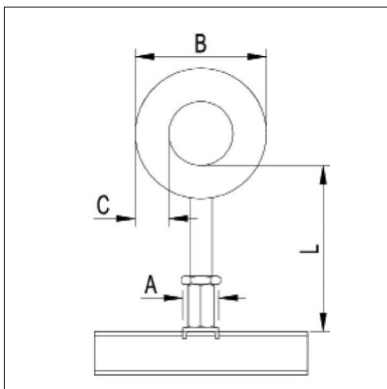

Type	nominal width [DN]	A [mm]	B [mm]	C [mm]	W [kg]	Quantity [Pack]	Part number
21/30	15	35	81	30	1,82	1	113904
27/30	20	35	87	30	1,82	1	113905
33/30	25	35	93	30	1,83	1	113906
42/30	32	35	102	30	1,84	1	113907
48/30	40	35	108	30	1,84	1	113908
60/30	50	35	120	30	1,93	1	113909
76/30	65	35	136	30	1,05	1	113910
89/30	80	35	149	30	1,10	1	113911
114/40	100	35	195	40	1,68	1	113912

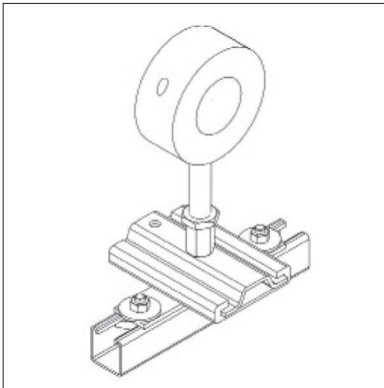

Assembly Group BG42 MS41-1/2"

Application

Assembly Group a guided pipe connection based on Chilled Water Clamp RB for Refrigeration and chilled water system, suitable for industrial requirements. The secondary steel interface is designed to easily connect the Sikla Channel MS 41. Height-adjustability is available via the Threaded Rod 1/2".

Scope of delivery

Sikla components are delivered as accumulated pieces goods assorted and separated for each item. The Threaded Rod is supplied by the meter (2m Rods) and has to be cut to length on site.

Installation

The installation of Sikla Assembly Groups should be done simultaneously with the line mounting on site.

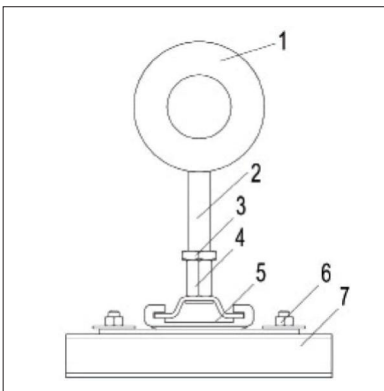

Parts list

- Pos. 1 Chilled Water Clamp RB
- Pos. 2 Threaded Rod GR 2m 1/2"
- Pos. 3 Locking Nut NT G 1/2"
- Pos. 4 Adapter AD IG/IG 1/2"/ 1/2"
- Pos. 5 Slide Set H3G-PL
- Pos. 6 T-Head Bolt TBO HZ41 M10x20
- Pos. 7 Channel MS (D) 41/41/2.5

Technical Data

Maximum height Lmax = 200 mm

Material

Plate components: Steel, hcp
 Screws and nuts: Steel, hcp
 Clamp material: Steel, electro-galvanised
 Insulation insert: PUR-foam (250 kg/m³, B2), $\mu=1200$, $\lambda = 0,045$ W/mK (0°C)
 Temperature range: -50°C bis +105°C

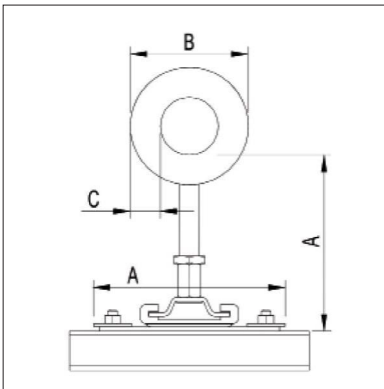

Type	nominal width [DN]	A [mm]	B [mm]	C [mm]	G [Kg]	Quantity [Pack]	Part number
21/30	15	190	81	30	2,07	1	110268
27/30	20	190	87	30	2,07	1	110269
33/30	25	190	93	30	2,08	1	110270
42/30	32	190	102	30	2,09	1	110271
48/30	40	190	108	30	2,09	1	110272
60/30	50	190	120	30	2,18	1	110273
76/30	65	190	136	30	2,30	1	110274
89/30	80	190	149	30	2,35	1	110275
114/40	100	190	195	40	2,93	1	110276

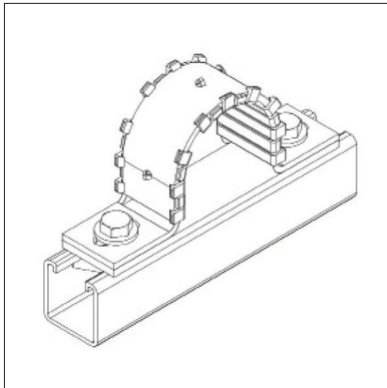

Assembly Group BG57 MS41

Application

Assembly Group for uninsulated pipe guide installation without special requirements. The U-Clamp is an alternative to a traditional U-Bolt and designed to be connected directly into the secondary support. The application of the Slide Plate will reduce the impact of friction on the surface of both pipe and support structure. Potential bi-metal corrosion between U-Clamp and pipe, for example by stainless steel pipes, will be avoided by a customised plastic insert which is from-lockef with the U-Clamp's mild steel.

Scope of delivery

Sikla components are delivered as accumulated pieces goods assorted and separated for each item.

Installation

The installation of Sikla Assembly Groups should be done simultaneously with the line mounting on site.

Parts list

- Pos. 1 U Clamp RUC I
- Pos. 2 Adapter NT CC41-M10
- Pos. 3 Washer US 10/125
- Pos. 4 Hexagon Bolt SKT M10 x 25
- Pos. 5 Channel MS (D) 41/41/2,5

Technical Data

Material

Plate material: Steel, hcp
 Inlay and slide plate: Thermoplastic plastics
 Temperature range: -20°C bis +90°C (to insert and slide plate)

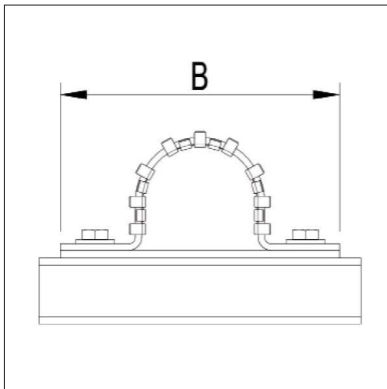
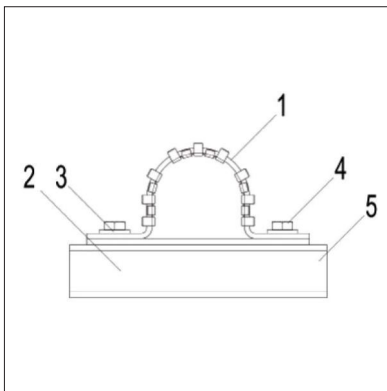

Type	nominal width [DN]	B [mm]	W [kg]	Quantity [Pack]	Part number
27	15	134	0,34	1	114670
33	20	140	0,35	1	114671
40	25	147	0,38	1	114672
48	32	155	0,40	1	114673
55	40	161	0,42	1	114674
67	50	173	0,47	1	114675
83	65	189	0,54	1	114676
95	80	202	0,58	1	114677
121	100	227	0,67	1	114678